

INNOVATION. PRECISION. TRUST.



401KW

EU Stage IIIA

6 cylinders

YUCHAI GENSET ENGINE

D500R3-CR-TA-612

Engineered for superior performance, the D500R3-CR-TA-612 delivers 360 kW of prime power with advanced turbocharged technology. This 6-cylinder 11.73L diesel engine combines high efficiency with robust construction for demanding power generation needs.

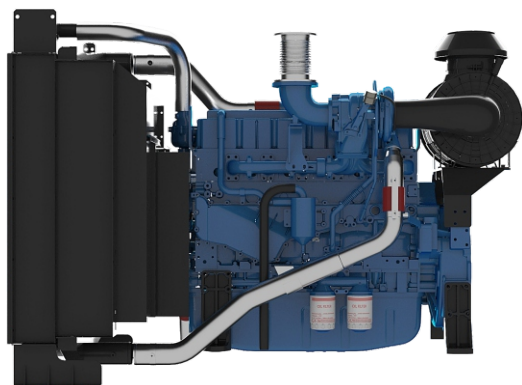

Main technical parameters

Number of cylinders	6
Configuration	Vertical, in-line
Aspiration	Turbocharged and intercooled
Combustion system	Direct injection
Compression ratio	14:1
Bore × Stroke	131x 145
Displacement	11.73L
Rotation	Counterclockwise (viewed from the flywheel end)
Fuel system	High Pressure Common Rail
Governor	ECU
Stability at constant load (ISO 8528-5 Class G3)	± +/- 0.5 %
50/60Hz switchable operation	NO
Electric system	24V
Tropical Radiator mounted on the engine	Ambient 50°C
Flywheel Housing	SAE1 /14"
Lubrication Oil capacity	37L
Coolant capacity	85L
Emission class	EU Stage IIIA

YUCHAIMOTOR.COM

The engine performance

Gross Engine Output 50Hz

PRP	401 kWm
ESP	441 kWm

Typical Generator Output 50Hz

PRP	360 kWe
PRP	450 kVA
ESP	500 kVA

Fuel consumption

STANDBY(ESP)	206.9 g/kWh	109.3 L/h
PRIME(PRP)	202.6 g/kWh	97.3 L/h
75% PRP (prime)	205.1 g/kWh	49.3 L/h
50% PRP (prime)	205.5 g/kWh	74.0 L/h

HVO synthetic fuel acceptance

Key Features

Main Features

- ✓ Compact design
- ✓ Good power density
- ✓ Durability
- ✓ Easy service & maintenance
- ✓ Low fuel consumption
- ✓ Wide selection of optional equipment
- ✓ Low noise
- ✓ Tailored cooling pack

Standard scope of supply

- ✓ Cast iron cylinder block c/w separate cast iron cylinder head
- ✓ Aluminum alloy pistons with gallery oil cooling
- ✓ Automatic belt tensioner, Lift eyes, Fixed front suspension
- ✓ Radiator with mechanical pusher fan, thermostatically controlled
- ✓ Large capacity oil pan, spin-on full-flow oil filter, oil dipstick
- ✓ High pressure common-rail system, multiple jets injectors, ECU
- ✓ Duplex fine fuel filters
- ✓ Side mounted turbocharger
- ✓ Rear mounted air filter with restriction indicator
- ✓ 24V DC electric system with 9kW starter
- ✓ 55A charging alternator
- ✓ Heat isolated exhaust manifold

Dimensions & Weight

Dimensions & Weight

Including radiator (dry weight)

2146

Length (mm)

1125

Width (mm)

1450

Height (mm)

1338

Weight (kg)

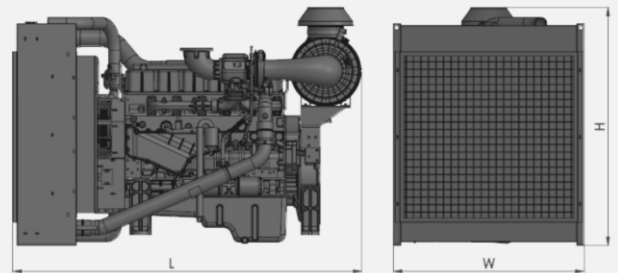

POWER DEFINITIONS:

ESP = STANDBY POWER

According to ISO8528 is maximum power available during variable electrical power sequence up to 200h of operation per year, permissible output over 24h operation should not exceed 70% ESP

PRP = PRIME POWER

According to ISO8528 is maximum power engine can deliver continuously for unlimited number of hours per year permissible output over 24h operation should not exceed 70% PRP

YUCHAIMOTOR.COM

**INTERNATIONAL
WARRANTY**

Prime Power

2 years with
no hours limitations

Standby Power

4 years or max. 1000 hrs
but not more than 300 hrs per year